



VERTICAL COMPONENT ANEMOMETER

FEATURES

- **Very Low Threshold**
- **Fast Response**
- **Photochopper Detector**
- **Built-In Signal Conditioning**
- **Minimal Induced Turbulence**
- **Optional Heater**

Climatronics' Vertical Component Anemometer (P/N 102236) is our latest generation of vertical wind speed sensors. It is an improved product superior in performance and directly interchangeable with our previous versions of component anemometers, P/N 101284 and P/N 101036, both which have been discontinued. Exceptionally low threshold and fast response are achieved through the use of mechanical features found in our proven F460 wind sensors. The anemometer body is slender and aerodynamic to ensure that minimal turbulence is introduced into the measured air stream.

The component anemometer may be supplied with either an expanded polystyrene (EPS) propeller featuring low threshold or a carbon fiber propeller for superior durability. Propeller rotation causes a 3-slot shutter to interrupt a solid-state light source. This pulse signal is processed by an internal signal conditioner which utilizes state-of-the-art surface mount technology.

The sensor produces a dual frequency and linear millivolt DC output. The DC output is identical to the DC generator output of our previous component anemometer (P/N 101284). Both signal outputs allow for full compatibility with Climatronics' and many other signal conditioning and data acquisition products. The component anemometer mates to its mount (P/N 102234) with a weatherproof connector identical to that of the previous component anemometer. The mount features a choice of three standard pipe adapters and includes a shielded signal cable prewired to the mating connector. The cable length may extend upwards of 1,000 ft. with no appreciable loss in signal strength or quality. The component anemometer and its propeller may be supplied with an optional NIST-traceable calibration (P/N 600025). An optional heater (P/N 101238) is available to prevent the build-up of snow and ice.



SPECIFICATIONS

PERFORMANCE

Accuracy	± 1.0% over range	
Threshold	G0: 0.5 mph (0.22 m/s)	Carbon Fiber
	G1: 0.3 mph (0.14 m/s)	EPS
Distance Constant	G0: 6.9 ft (2.1 m)	Carbon Fiber
	G1: 3.2 ft (1.0 m)	EPS
Operating Range	±40 mph (±20 m/s)	

ELECTRICAL

Signal Output	±500 mV corresponding to 1800 rpm = 20.00 mph (8.94 m/s)
Analog Frequency	90 Hz corresponding to 1800 rpm = 20.00 mph (8.94 m/s)
Power Requirements	6.0 mA at +12 VDC (±3 VDC)

PHYSICAL

Height	30 in (76.0 cm)
Body Diameter	1 in (2.54 cm) tapering to 0.375 in (0.95 cm)
Propeller Diameter	8 in (20.3 cm) (Nominal)
Weight	Sensor <1 lb (0.45 kg)
	Mount 1 lb (0.45 kg)
Mounting	102234-G0 for 1¼ in IPS pipe
	G1 for 1 in IPS pipe
	G2 for ¾ in IPS pipe

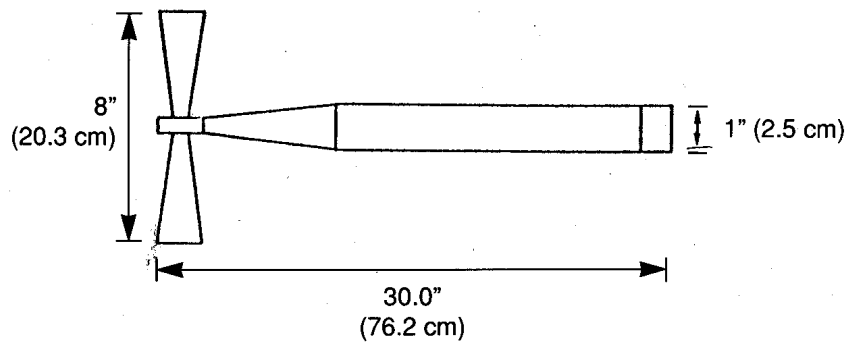

Climatronics Corporation
140 Wilbur Place
Bohemia, NY 11716-2404

TEL: 631-567-7300
FAX: 631-567-7585
E-Mail: sales@climatronics.com