



WIND MARK III WIND SENSOR

FEATURES:

- **Low Threshold**
- **Low Cost**
- **Low Power**
- **Lightweight**
- **Optional External Heaters**

Climatronics' Wind Mark III (WM-III) Wind Sensors combine accuracy and reliability with low cost. They also meet the Environmental Protection Agency (EPA) Prevention of Significant Deterioration (PSD) requirements and are well suited for general wind monitoring applications. The WM-III sensor is also available as a wind speed only (P/N 100108-1) or wind direction only (P/N 100108-2) instrument. The WM-III sensor is sealed per IP 65.

Wind speed is sensed by a three-cup anemometer and converted to an electrical signal by a solid-state photo chopper. A counter balanced wind vane coupled to a precision, low torque potentiometer senses wind direction. The sensors use stainless steel precision ball bearings for maximum life and low threshold. Traceability to NIST is available as an option for each anemometer cup assembly by comparison testing against an NIST-traceable transfer standard in our wind tunnel test facility. The sensors and their crossarm are an integral unit. The crossarm mounts on a 3/4-inch IPS vertical pipe stub (1.05 inch O.D.). Orientation of the crossarm is along an East-West plane.

The LEXAN cup (P/N 102138) and magnesium vane (P/N 101944) combination are standard. The heavy-duty aluminum cups (P/N 101282), and heavy-duty magnesium vane (P/N 101292) are optional. A sensor transit case (P/N 100255) is available. Climatronics Universal Interface Module (UIM), IMP-800 series of digital data acquisition units, or almost any data logger/data acquisition system currently available on the market are easily interfaced with the Wind Mark III sensor.

The Wind Mark III sensor can be provided with a 4 - 20 mA current loop output. In this configuration, the part number is 101908. Please consult the Current Loop Wind Sensor data sheet for additional details.

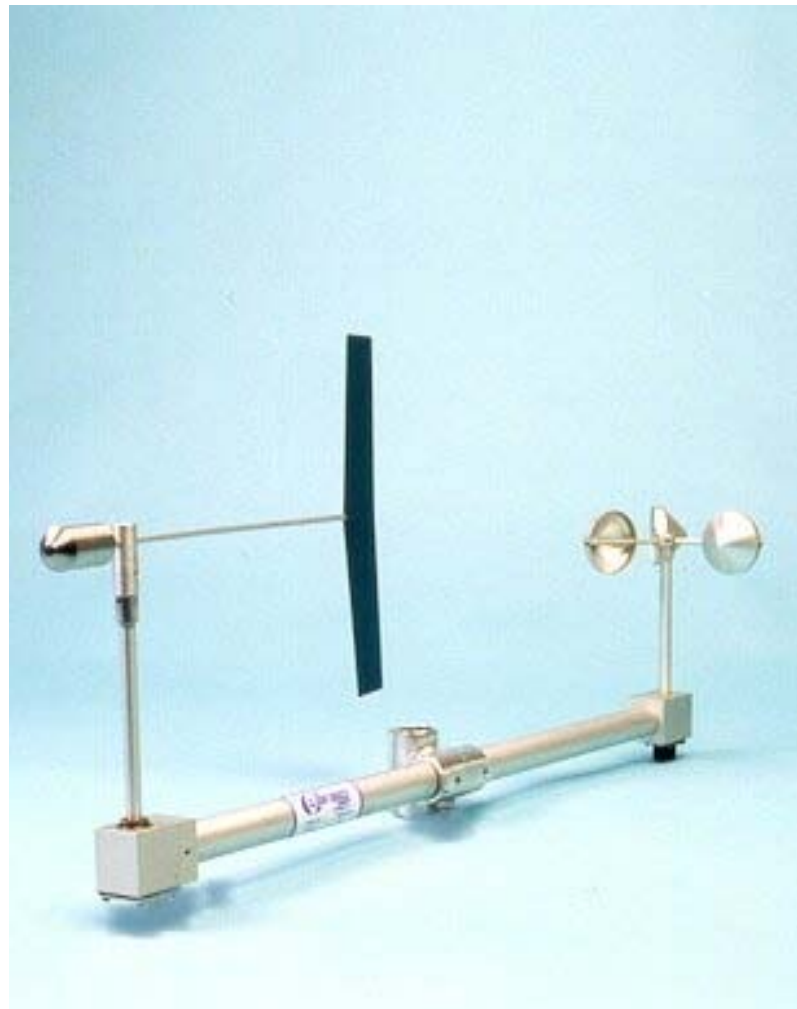

SPECIFICATIONS

PERFORMANCE

	WM-III Wind Speed	WM-III Wind Direction
Accuracy	0.25 mph (± 0.11 m/s) or $\pm 1.5\%$ of true air speed (whichever is greater)	± 3 degrees
Threshold	<1.00 mph (0.45 m/s)	< 1.0 mph (0.45 m/s)
Distance Constant	102138 LEXAN <2.4m (8.0 ft.) 101286 HD Aluminum <4.6m (<15.0 ft.)	101944 Standard <2.4m (8.0 ft.) 101292 Heavy Duty <4.5m (<15.0 ft.)
Damping Ratio	N/A	>0.4 to 0.6 at 10° initial angle of attack
Operating Range	0-125 mph (0-55 m/s)	0 to 360 degrees - mechanical

ELECTRICAL

Signal Output	Nominal 2.0 Vpp into 4.7 Kohm, frequency proportional to wind speed, amplitude dependent on supply voltage	Variable DC voltage, magnitude proportional to wind direction
Power Requirements	5-15 Vdc @ 1 mA nominal	Max. 5 mA through 2 Kohms

PHYSICAL*

Weight	Less than 2 lbs. (0.9 kg.)	
Turning Radius	3.75 inch (9.5 cm)	17.5 inch (44.4 cm)
Operating Temperature	-40° to +140° F (-40° to +60° C)	

* The sensor is sealed per IP 65.

SENSOR HEATER SPECIFICATIONS

External 20 Watts per sensor thermostatically controlled
110/60 VAC/Hz, P/N 101234-G0 or 220/50 VAC/Hz, P/N 101234-G1

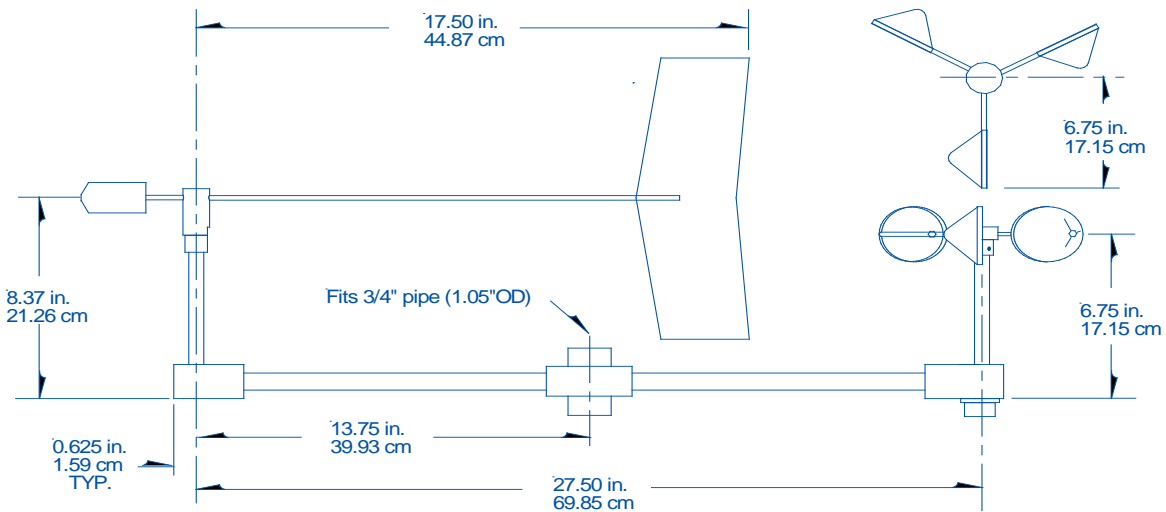

Climatronics Corporation
140 Wilbur Place
Bohemia, NY 11716-2404

TEL: 631-567-7300
FAX: 631-567-7585
E-Mail: sales@climatronics.com