



CURRENT LOOP WIND SENSOR, P/N 101908

FEATURES:

- **Low Threshold**
- **Low Cost**
- **Low Power CMOS Design**
- **Lightweight**
- **4 - 20 mA Outputs**
- **Optional External Heaters**

Climatronics' P/N 101908 Current Loop Wind Sensors is a 2-wire, 4-20 mA output version of our popular P/N 102083, Wind Mark-III wind sensor.

Current loop outputs are ideal wherever there is an application involving more than a few hundred feet of separation between the sensor and the signal conditioners, data acquisition, or display systems. They are essentially immune to electrical noise and require less wiring than conventional sensors, thereby reducing both the total cost and time of installation of a turnkey system.

The Current Loop Sensors meet the Environmental Protection Agency's (EPA) Prevention of Significant Deterioration (PSD) requirements. They are also well suited for general wind monitoring applications.

Wind speed is sensed by a three-cup anemometer and is converted to an electrical signal by a 20-hole photo chopper, which uses a solid-state light source for maximum reliability. A counterbalanced wind vane coupled to a precision, low torque potentiometer senses wind direction. Both the wind speed and wind direction sensors use stainless steel precision ball bearings for maximum life and low threshold. Traceability to NIST is available as an option for each anemometer cup assembly by comparison testing against an NIST transfer standard in our wind tunnel test facility.

The sensors and their crossarm are an integral unit. The pre-wired crossarm mounts on a 3/4-inch IPS vertical pipe stub (1.05 inch O.D.). Orientation of the crossarm is along an East-West plane.

A 24 VDC/50 mA source is required to operate the wind set over a four-conductor cable, which can be up to a mile in length*. The 24 VDC/50 mA power can be provided either by a customer-supplied source, or from a display or signal conditioner supplied by Climatronics. Optional external heaters for both sensors are available. These heaters consume



approximately 40 watts of power and are thermostatically controlled. The optional external heaters require customer-supplied AC power. The Wind Mark III is sealed per IP 65.

SPECIFICATIONS

	Wind Speed	Wind Direction
PERFORMANCE		
Accuracy	0.25 mph (± 0.11 m/s) or $\pm 1.5\%$ of true air speed (whichever is greater)	± 3 degrees
Threshold	<1.00 mph (0.45 m/s)	< 1.0 mph (0.45 m/s)
Distance Constant	102138 LEXAN <2.4m (8.0 ft.) 101286 HD Aluminum <4.6m (<15.0 ft.) 100160 Stainless Steel <2.4m (8.0 ft.)	101944 Standard <2.4m (8.0 ft.) 101292 Heavy Duty <4.5m (<15.0 ft.)
Damping Ratio	N/A	>0.4 to 0.6 at 10° initial angle of attack
Operating Range	0-125 mph (0-55 m/s)	0 to 360 degrees - mechanical
ELECTRICAL SPECIFICATIONS		
Signal Output	4-20 mA proportional to 0 - 100 mph	4-20 mA proportional to 0 - 360°/540°
Power Requirements	24 VDC* @ 20 mA maximum	24 VDC* @ 20 mA maximum
PHYSICAL SPECIFICATIONS**		
Weight	Less than 2 lbs. (0.9 kg.)	Less than 2 lbs. (0.9 kg.)
Turning Radius	3.75 inch (9.5 cm)	17.5 inch (44.4 cm)
Operating Temperature	-40° to +140° F (-40° to +60° C)	-40° to +140° F (-40° to +60° C)
SENSOR HEATER SPECIFICATIONS		
External	115 Vac/60Hz 20 Watts per sensor (P/N 101234)	

* Longer cable lengths or higher resistance loads may require higher voltage.
 ** Sealed per IP 65

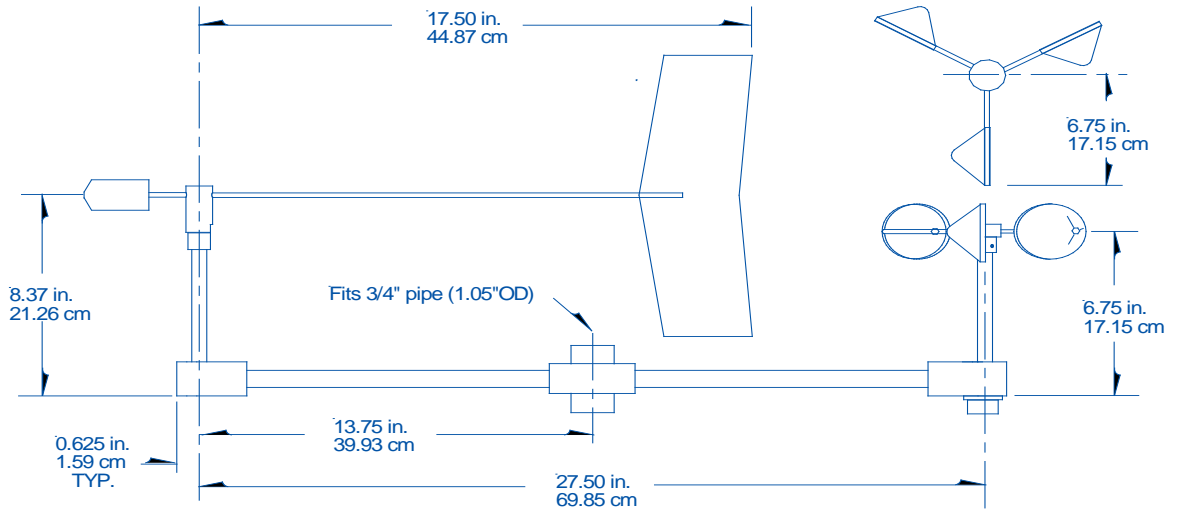

Climatronics Corporation
 140 Wilbur Place
 Bohemia, NY 11716-2404

TEL: 631-567-7300
 FAX: 631-567-7585
 E-Mail: sales@climatronics.com