

SIGNAL CONDITIONING

MANUAL - GUY KIT MANUAL P/N M101004 Rev A

1.0 INTRODUCTION

Tower guying must be performed after the base section has been installed (see Installation Instructions Towers and Bases) and prior to equipment installation.

NOTE: These instructions apply to towers between 30 and 70 feet that are on level ground. If the terrain drops off appreciably where the ground anchors are located, there may not be enough guy wire to perform the installation.

Two people are required to install the guy kit. To facilitate the installation, we recommend that this be performed on ground that is not frozen. Tools needed to install the guy kit include:

- small shovel
- screw driver
- pliers or 10 inch crescent wrench
- wire cutters (for 1/8 inch galvanized steel cable)
- torque bar (approximately 1 inch x 3 feet)

Refer to attached drawing No. 101004 illustrating the following instructions. Read through all the instructions once before starting.

1.1 Specifications

Not Applicable.

2.0 INSTALLATION

1. Based on the tower height, mark off distance "A" from each of three base legs to determine the anchor points. It is critical that 120° separate each distance measured from the base

legs. Refer to Figure 1, 2, and 3 on Drawing 101004.

2. Where the anchors have been located, dig a shallow hole (approximately 6 inches) at a 45° angle away from the tower as shown in Detail "B".
3. Slide the torque bar into the eye of the anchor.
4. With one man holding the anchor at 45°, the other man now screws the anchor into the ground in a clockwise direction with the aid of the bar. Continue this operation until the bottom of the anchor eye is approximately 6 inches from ground level.
5. Repeat steps 2 - 4 for the other two tower corners.
6. A single length of guy cable is supplied which must be cut according to the dimensions mandated by the tower height. See the table on Drawing 101004 for dimensions "D" and "E". Cut the cable in accordance with the following table.

TABLE I

If "D" or "E"

Dimension is (In feet):	Cut Cable Length to (in feet):
39	41.5
47	50.0
53	56.5
58	61.5
64	68.0
65	69.0
78	83.0
89	94.0

SIGNAL CONDITIONING

MANUAL - GUY KIT MANUAL P/N M101004 Rev A

NOTE: Three sets of each cable length are required.

7. Assemble all tower sections and connect to the two hinged base legs with the tower laying on the ground. Connect the guy cables to the tower as shown in Details "C" and "A". The clamps are to be put on in accordance with Note 1 on the drawing. Attach the end clamp first. The second clamp should be as close to the loop as possible.
8. At this time, equipment that will be mounted on the upper portion of the tower can be installed and the tower raised.
9. Open up the turnbuckles to their maximum length, approximately 10 1/2 inches.
10. Spread open the thimble, and slip it through one of the turnbuckle eyes.
11. Bring the guy cable around the thimble and clamp it as shown in Detail "B". The clamps are to be put on in accordance with Note 1 on the drawing. Trim the cable if required, and attach the end clamp first. The second clamp should be as close to the thimble as possible.
12. Remove the screw pin from the shackle and put the loop end around the eye of the anchor as shown in Detail "B". Slide the pin back through the shackle and the eye of one or both turnbuckles. Screw to the shackle securely.

13. Tension the guy wires by taking up on the turnbuckles. Apply tension gradually and uniformly to each guy wire. Tensioning any one wire too much will cause the tower not to be vertical. Guy tension should be approximately 200 lbs.
14. Retighten the nuts on the clamps, if required. Periodically check the guy wire tension and retighten the nuts on the clamps.
15. To lower the tower, loosen all the guy wires. Remove the screw pin from the shackle having the guy wire(s) coming from the non pivoting tower leg. Remove the leg bolt and lower the tower.

3.0 I/O CONNECTIONS

Not Applicable.

4.0 USER DEFINED OPTIONS

Not Applicable.

5.0 USER INTERFACE

Not Applicable.

6.0 THEORY OF OPERATION

Not Applicable.

7.0 CALIBRATION/MAINTENANCE

Not Applicable.

8

7

6

5

4

3

1

REV. NO.		DESCRIPTION		DATE	APPROVED
A	ECN 2578	JR	9/24/85	RJC	
B	ECN 3154	SC	2/13/88	S.F.	
C	ECN 4092		7-9-91	S.F.	
D	ECN 5461		7-20-05	D.A.	

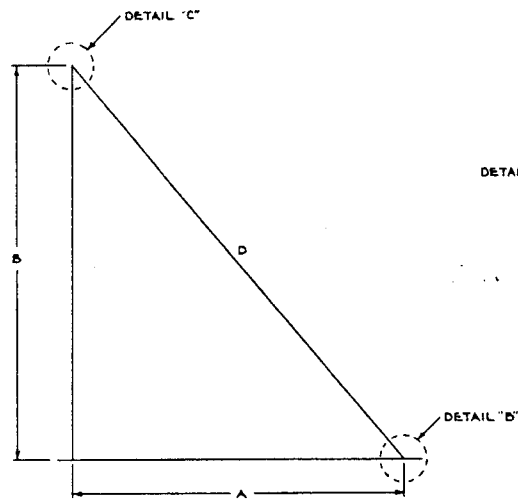

FIGURE 1

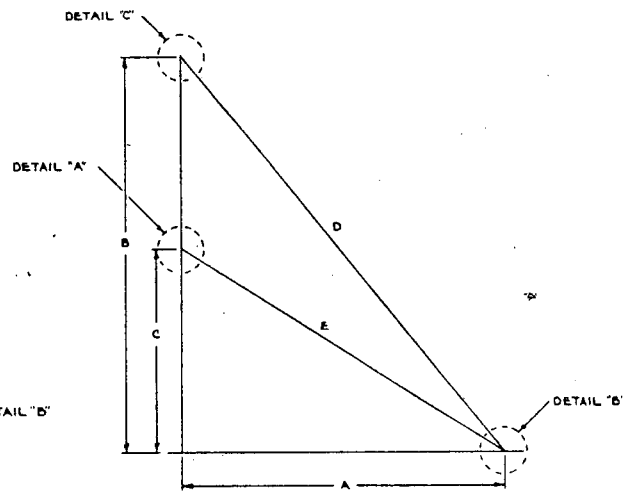

FIGURE 2

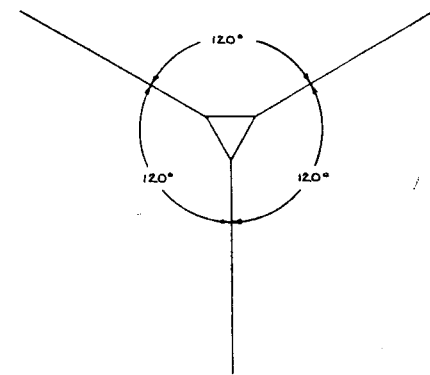
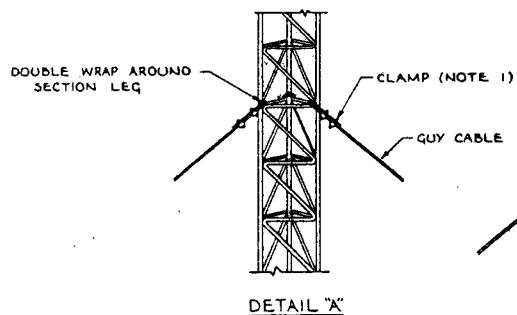
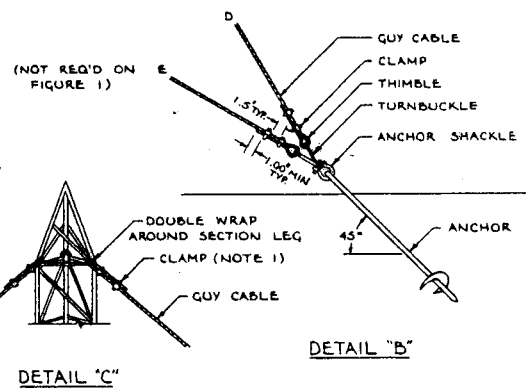

FIGURE 3

TOWER HEIGHT	FIG. NO.	DIMENSION "FT"				
		A	B	C	D	E
10 FT	1,3	8	10	-	14	-
20 FT	1,3	16	20	-	28	-
30 FT	1,3	25	30	-	39	-
40 FT	1,3	35	40	-	53	-
50 FT	2,3	40	50	25	64	47
60 FT	2,3	50	60	30	78	58
70 FT	2,3	55	70	35	89	65
80 FT	2,3	60	80	40	100	72



DETAIL "A"



DETAIL "B"

DETAIL "C"

NOTES:

1. BASE OR SADDLE TO BEAR ON LIVE END OF CABLE - U-BOLT ON SHORT OR DEAD END.

REV. NO.	DATE	DESCRIPTION	APPROVED	DATE
1				
PARTS LIST				
INTERNAL CHECKED BY DATE		APPROVED DATE		
NEXT ASSY USED ON		GUY KIT		
APPLICATION		PART NO. 101004 REV. D		

GUY KIT
P/N 101004 Rev D
PARTS LIST
Sheet 2 of 2

ITEM	SYM.NO	QTY	PART NO.	DESCRIPTION
1, 2, 3, 4		0.0	101004G	SEE G LIST
5		3.0	19125	ANCHOR SHACKLE
6		3.0	4345	SCREW ANCHOR
		12.0	20905	CLAMP
		3.0	21016	TURNBUCKLE EYE TO EYE 3/8 IN
		3.0	40400	THIMBLE, GUY

SEE G LIST
P/N 101004G Rev
PARTS LIST
Sheet 1 of 1

ITEM	SYM. NO	QTY	PART NO.	DESCRIPTION
		1.0	101004G1	10 FOOT TOWER
		1.0	101004G2	20 FOOT TOWER
		1.0	101004G3	30 FOOT TOWER
		1.0	101004G4	40 FOOT TOWER
		1.0	101004G5	50 FOOT TOWER
		1.0	101004G6	60 FOOT TOWER
		1.0	101004G7	70 FOOT TOWER
		1.0	101004G8	80 FOOT TOWER