

SENSORS

MANUAL - F460 WIND DIRECTION SENSOR P/N M100076 Rev C

1.0 INTRODUCTION

Climatronics' F460 Wind Direction Sensor, P/N 100076, is designed to provide low starting threshold, fast dynamic response and high accuracy over a wide operating range under adverse environmental conditions. The Sensor consists of a counterbalanced, lightweight vane attached to a shaft which is coupled to a precision low torque potentiometer. Wind direction via vane position is converted to a proportional dc voltage by a potentiometer.

1.1 SPECIFICATIONS

Accuracy: $\pm 2^\circ$

Threshold: 0.22 m/s (0.5 mph)

Distance Constant: 1.1 m (3.7 ft) of air max.

Operating Range: $0^\circ - 360^\circ$

Damping Ratio: 0.4 at 10° initial angle of attack

Operating Temperature: -40° to 60°C (-40° to 140°F)

Power Requirement: 1 mA, max, through 10K ohms

Signal Output: Variable dc voltage, magnitude proportional to wind direction

Size: 5.7 cm (2.25 inch) maximum diameter

Turning Radius: 41.9 cm (16.5 inch)

Height: 29.2 cm (11.50 inch)

Weight: Less than 0.9 kg (2 lbs.)

2.0 INSTALLATION (Refer to Fig 1 & 2)

Be sure to locate the Sensor in a clear, unobstructed area so as to minimize or eliminate any turbulent effects caused by local obstructions (e.g., trees, buildings, etc.) The Sensor is mounted on the prewired F460 Crossarm, P/N 101994. The connector keys and the notch in the lower part of the Sensor body are matched to the alignment pin of the crossarm. Secure the Sensor by tightening the two set screws located at its base.

Attach the vane by matching the vane hub with the shaft hub and lightly tightening the set screws.

Note: Applications of Anti-Seize compound on the set screws will facilitate disassembly should it become necessary.

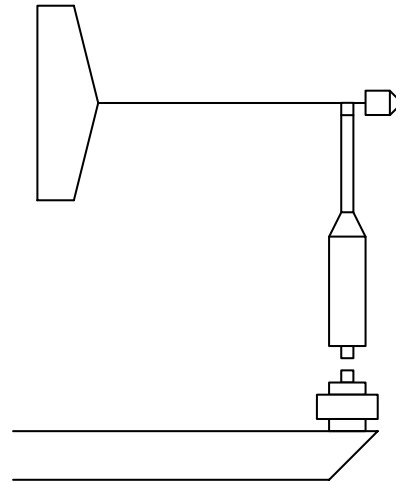

Figure 1

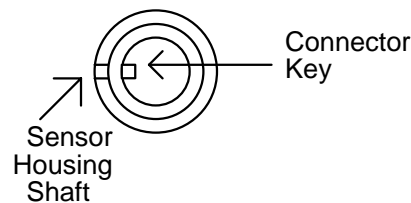
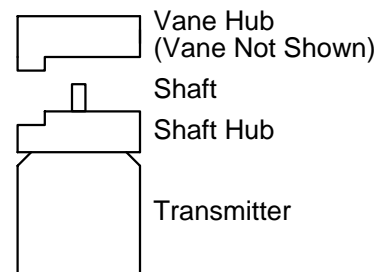

Figure 2

CAUTION !! The Wind Direction Sensor must be properly oriented with respect to north. For instructions, refer to the Crossarm manual, P/N 101994.

3.0 INPUT/OUTPUT CONNECTIONS

The Sensors' connector pin designations are as follows:

<u>PIN</u>	<u>Function</u>
A	Wind Direction Output
B	*Heater +
C	Ground
D	*Heater -
E	Not Used
F	Pot. +V Input

*Internal heater connections, optional item.

4.0 USER DEFINED OPTIONS

Both internal and external sensor heaters are available. The internal heater is a continuously operating device which consumes 2W per sensor of the 12Vdc sensor power. This heater option is designed to minimize internal moisture build up and requires factory installation. The external heater is thermostatically controlled and is designed to minimize sensor freeze-up in cold environments. This heater option is powered by 110 Vac, requires approximately 20W per sensor, and may be added by the user as a field modification.

5.0 USER INTERFACE N/A

6.0 THEORY OF OPERATION

Please refer to drawing number 400097, the schematic diagram of the Wind Direction Sensor. Vane position is sensed by a precision low-torque potentiometer, and sent to the translator as a dc voltage. A 1/32 amp fuse is connected in series with the potentiometer for protection from excess current flow through the potentiometer.

CAUTION !! When testing the potentiometer, limit the current to a maximum of 25 mA.

7.0 CALIBRATION

Adjustment of the Wind Direction Sensor is required only if either the hub (see Drawing No. 100076) has slipped relative to the shaft assembly or if the potentiometer is replaced. If adjustment is required, first calibrate the Wind Direction Signal Conditioner; second, rotate the Sensor shaft until the flat section on the hub is exactly perpendicular to a line drawn through the center of the Sensor and the alignment mark on the Sensor base.

Temporarily secure the cap in place with a piece of tape. Third, loosen the two set screws that hold the hub to the shaft and rotate the shaft until a reading

of 180° is obtained on a readout device. A voltmeter may also be used for this purpose. It should read one third of the Signal Conditioner's full scale output ($\pm 0.5\%$) for a 0-540° Signal Conditioner. Finally, the set screws should be tightened to lock the cap in place and then the tape removed.

8.0 MAINTENANCE

If bearing or potentiometer replacement is necessary, proceed as follows. Drawing 100076 will help in locating the parts described below. Read through the whole procedure before starting.

1. Remove the vane by loosening the two set screws that hold it to the shaft and lifting the vane off the shaft.
2. Remove the transmitter cover by pulling it toward the base with a slight twisting motion.
3. Loosen the upper set screw in the potentiometer coupling with a 1/16 Allen Key.
4. Allow the shaft to slide out through the top end of the column.
5. Remove and discard the old bearing. If it is necessary to push the bearing out from the bottom of the seats (using a long thin rod or the shaft assembly) the potentiometer must be removed. Refer to the note below before continuing. Pushing lightly all around the bearing is better than too much pressure on one side of the bearing.

NOTE: To remove the potentiometer, follow this procedure:

- a. Using a Phillips head screwdriver, remove the two top screws from the transmitter support. This frees the upper portion of the transmitter.
- b. Using a flat tip screwdriver, loosen the three retaining clamps and slide the potentiometer out.

After completing the bearing change, re-install the potentiometer by reversing the above steps.

6. Place a new bearing on the shaft and guide the shaft back into its hole from the top until the bearing is seated.
7. Tighten the set screw in the coupling.
8. Adjust the hub as described in Section 7.

9100076

REVISIONS

LTR	DESCRIPTION	DATE	APPROVED
B	ADD (21-25) REF	3/19/76 GA	
C	ECN 0930	12/15/76 RA	
D	ECN 0938	4-2-80 KC	
E	ECN 1205	11/20/80 KC	
F	ECN 1299	1/21/81 KC	
G	ECN 1747	KC 5/4/82	
H	ECN 1827	KC 8/3/82	

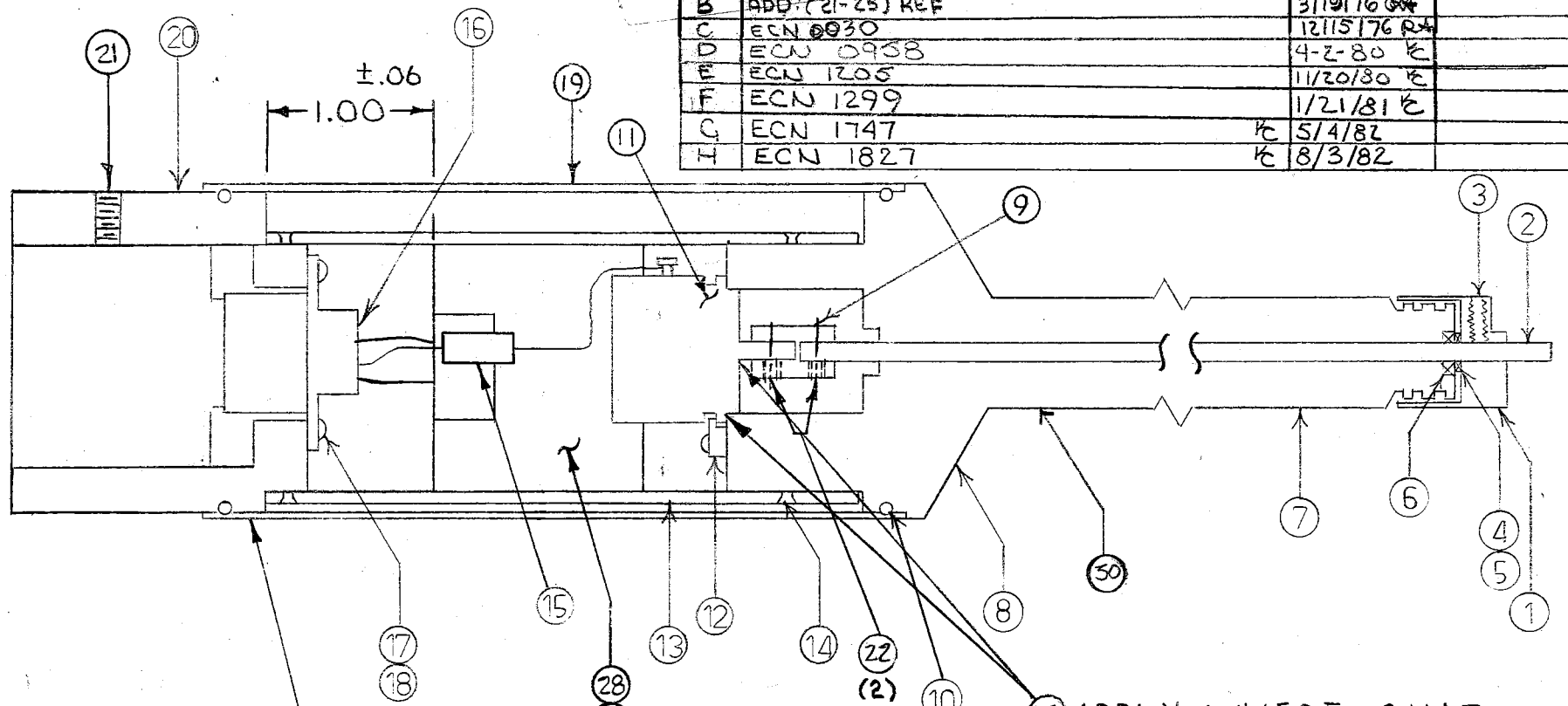

CUT END OF COVER INSTALLED THIS END

25 APPLY WHERE SHAFT EMERGES FROM HOUSING, & ON MOUNTING FLANGE.

SLOT

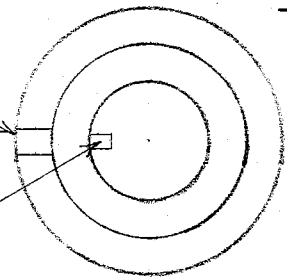

CONNECTOR KEY

REV	ECN	DATE	TOLERANCES UNLESS OTHERWISE SPECIFIED
J	2016	3-18-83	FRACTIONS DEC ANGLES
K	2045	3-30-83	± ± ±
L	2222	12/5/83 E	
M	2253	11/4/84 E	
N	2289	2/16/84 E	
O	2897	9/8/86	
P	3176	2-23-88 S.F.	

CLIMATRONICS CORP.

F460 WIND DIRECTION TRANSMITTER ASS'Y. DRW

V	5594	9-12-06
U	9420	4/15/05
T	5032	8/3/01
S	4972	11-3-00

CONNECTOR ORIENTATION BOTTOM VIEW

APPROVALS	DATE
DRAWN SDS	5-14-74
CHECKED	

SCALE	SIZE	DRAWING NO.
		A100076 V
DO NOT SCALE DRAWING		SHEET 1 OF 4

REVISIONS

REV.	DESCRIPTION	DATE	APPROVED

400568-3 POT WIRING

401378 POT WIRING

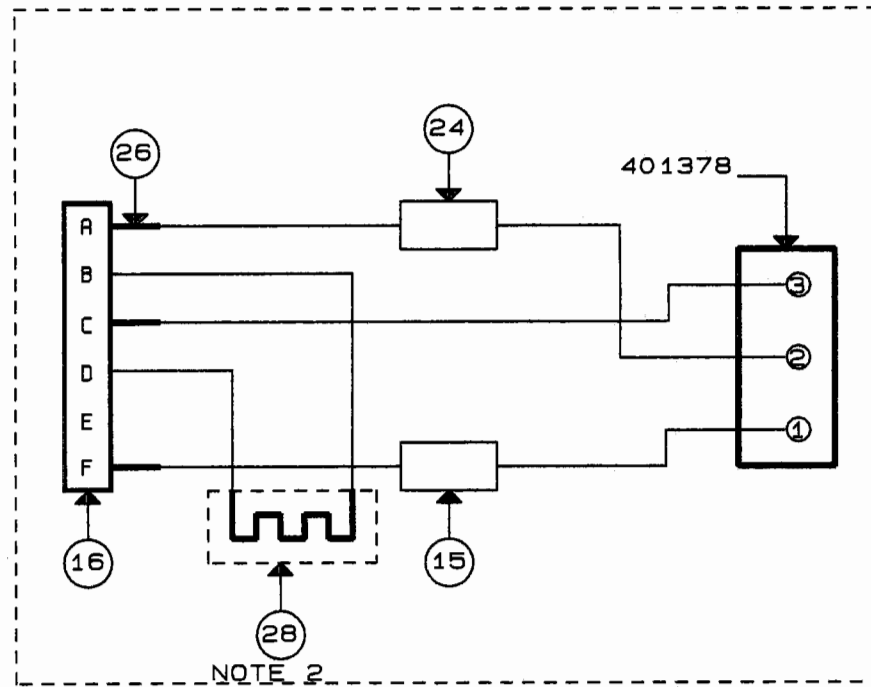
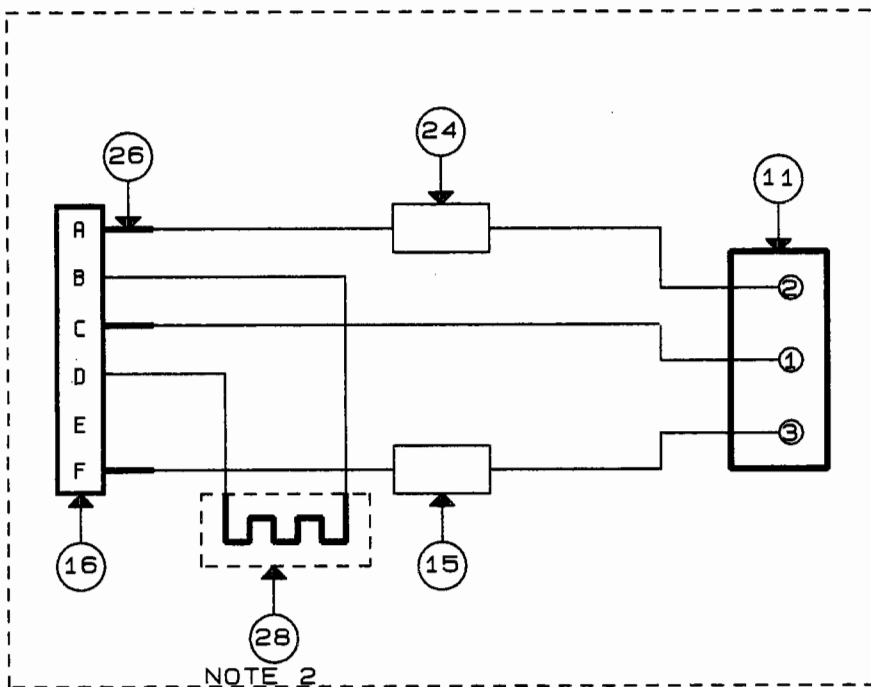

NOTE:

1. WIRE USED ON THIS ASSEMBLY IS 22 GA. WHITE/BLACK. 3" LG.
2. HEATER OPTION
3. ITEM 24 & 15 HAVE SMALL SERVICE LOOP.

ARESICO, HICKSVILLE, N. Y. - OGILVIE 89911

UNLESS OTHERWISE SPECIFIED DIMENSIONS ARE IN INCHES TOLERANCES ARE:		CONTRACT NO.					
FRACTIONS ±	DECIMALS .XX ± .XXX ±	ANGLES ±					
MATERIAL		APPROVALS	DATE	F460 WIND DIRECTION TRANS.			
FINISH		DRAWN D. ADAMS	11/80				
NEXT ASSY	USED ON	CHECKED		SIZE A	CAGE CODE 52332	DWG. NO. 100076	REV. V
APPLICATION	DO NOT SCALE DRAWING	ISSUED		SCALE		SHEET 2 of 4	

F460 WIND DIRECTION SENSOR
P/N 100076 Rev V
PARTS LIST
Sheet 3 of 4

ITEM	SYML NO	QTY	PART NO.	DESCRIPTION
1		1.0	101357	F460 WIND DIRECTION CAP
2		1.0	500022	SHAFT, F460 WIND DIRECTION
3		2.0	SC8-5	SET SCREW 4-40 x 5/32
4		1.0	02-12	RING RETAINER
5		0.0	SS1	SPACER KIT
6		1.0	500096	BEARING
7		1.0	500107	COLUMN, F460
8		1.0	500108	TOP, F460
9		1.0	500187	SHAFT COUPLING F460
10		2.0	2-031	O-RING, BUNA N, 60 DUROMETER
11		1.0	400568-3	POT 10K 5% F460
12		3.0	SQ-8	CLAMP, SYNCHRO
13		1.0	500109	SUPPORT TRANSMITTER F460
14		4.0	MS24693-C2	4-40 x 1/4 100 DEG. FH SCREW
15		1.0	RC07GF160J	RES 16 OHM 5% 1/4W
16		1.0	MS3102A14S-6P	CONNECTOR, RECEPTACLE
17		4.0	MS51957-14	SCREW 4-40 x 5/16 FH
18		4.0	MS35338-135	WASHER, LOCK SPLIT #4
19		1.0	500111	TRANSMITTER COVER F460
20		1.0	500110	BASE, F460
21		2.0	SC10-4	BR. TIP SET SCREW 1/4-20x 3/16
22		2.0	SC6-3	SCREW 6-32 x 1/8 HEX HD

Notes: ITEM 26, TUBING TO BE CUT TO 1/2 INCH LENGTHS - 3 PER ASSEMBLY
ITEMS 5,25,27,30 ARE TO BE USED AS REQUIRED
DP-190 MAY BE SUBSTITUTED FOR DP-125

F460 WIND DIRECTION SENSOR
P/N 100076 Rev V
PARTS LIST
Sheet 4 of 4

ITEM	SYM.NO	QTY	PART NO.	DESCRIPTION
23		0.0	100076G	SEE G LIST
24		1.0	RN55C2431F	RES 2.43K 1% 1/10W
25		0.0	21030	SYNTHETIC LUBRICANT, 3 OZ TUBE
26		0.0	PVC-105-10	TUBING, CLEAR AWG#10
27		0.0	TFE-200-22	22AWG TEFLON SLEEVING
28,29		0.0	100076H	SEE H LIST
30		0.0	DP-125	SCOTCH-WELD EPOXY ADHESIVE
		0.0	400097	SCHEMATIC

SEE G LIST
P/N 100076G Rev
PARTS LIST
Sheet 1 of 1

ITEM	SYM. NO	QTY	PART NO.	DESCRIPTION
		1.0	100076G0	VINYL VANE ASSEMBLY
		1.0	100076G1	F460 MAGNESIUM VANE ASSY.

SEE H LIST
P/N 100076H Rev
PARTS LIST
Sheet 1 of 1

ITEM	SYM.NO	QTY	PART NO.	DESCRIPTION
		0.0	100076H0	NO INTERNAL HEATER
		1.0	100076H1	HEATER

A400097G

REVISIONS			
LTR	DESCRIPTION	DATE	APPROVED
B	ADDED "NEXT ASSY" ECN 0958	4-2-80	
C	ADDED "CR1," "CR2" ECN 1204	12/12/80	
D	GHG RI PIN NOS. ECN 1506	7/23/81	
E	ECN 1747	5/4/82	
F	ECN 1827	8/3/82	
G	ECN 4972	11/6/00	

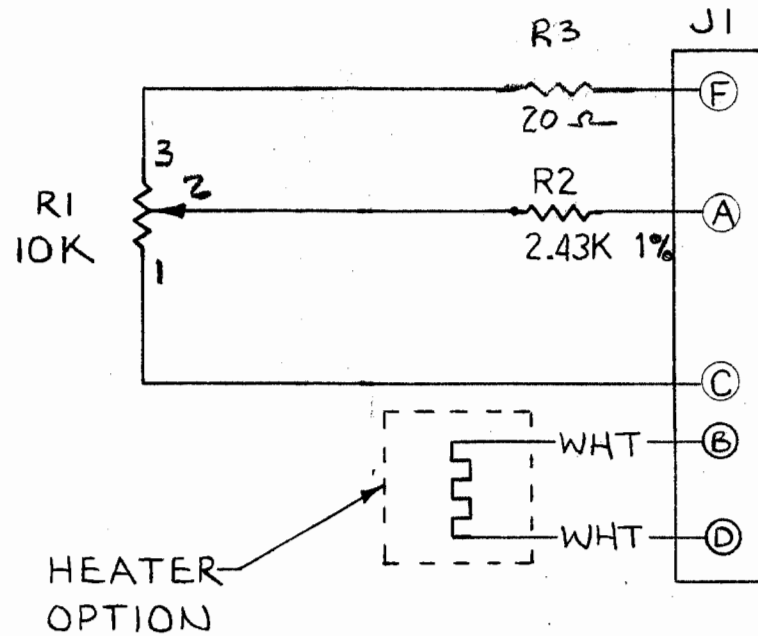

TOLERANCES UNLESS OTHERWISE SPECIFIED	
FRACTIONS	DEC ANGLES
±	± ±
APPROVALS	DATE
DRAWN S.D.S.	5-14-74
CHECKED	
NEXT ASSY	
100076	

CLIMATRONICS CORP.

F460 WIND DIRECTION TRANSMITTER

SCALE	SIZE	DRAWING NO.	
		A400097	G

DO NOT SCALE DRAWING SHEET

VINYL VANE ASSEMBLY
P/N 10007600 Rev A
PARTS LIST
Sheet 1 of 1

ITEM	SYM.NO	QTY	PART NO.	DESCRIPTION
23		1.0	101907	VANE ASSY, F460 FAST RESPONSE

F460 MAGNESIUM VANE ASSY.

P/N 10007601 Rev

PARTS LIST

Sheet 1 of 1

ITEM	SYM. NO	QTY	PART NO.	DESCRIPTION
23		1.0	101208	F460 VANE ASSEMBLY (MAGNESIUM)

HEATER
P/N 100076H1 Rev
PARTS LIST
Sheet 1 of 1

ITEM	SYM. NO	QTY	PART NO.	DESCRIPTION
28		1.0	101263	F460 INTERNAL HEATERS 2 WATT
29		1.0	999	RTV, DOW CORNING